

18650 BMS 3S/4S 40A 60A Li-ion Lithium Battery Charger Protection Board For Drill Motor 11.1V 12.6V/14.8V 16.8V Enhance/Balance

Charging voltage:	DC 12.6V~13.6V
Balance Version Product size:	41*61*4mm
Enhance Version Product size:	41*55*4mm
Continuous charging current:	up to 20A

Description:

Continuous discharge current: 40A maximum (if the heat dissipation environment is not good, please reduce the load current)

Applicable choice: applicable to the nominal voltage of 3.7V, fully charged 4.2V lithium battery (including 18650, 26650, polymer lithium battery), can be drilled below 170W

Note:

1: Successfully start the drill requires 3 10C-20C power batteries, or 6 5C-10C power batteries (recommended power battery models: sony vtc4, vtc4A, vtc5A, vtc6) 0V and 12.6V cable, use Copper wire of 3 square millimeters or more (nickel sheets cannot be used)

2: Strictly connect 0V, 4.2V, 8.4V, 12.6V according to the diagram. Do not touch any components on the board when soldering the wire. Do not intentionally short circuit.

3: When soldering the battery for the first time or when charging is in progress, as long as the single battery exceeds 4.2V, the "430" resistor will heat up and discharge (discharge to about 4.19V to stop heating). If the "430" resistor is severely hot, check if the wrong line is connected.

Hardware preparation:

Prepare 3S 12.6V 40A lithium battery protection module, battery, power supply, high power load resistor



3S 40A
Enhanced Edition

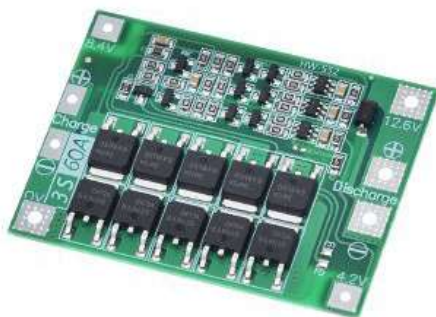

3S 60A
Enhanced Edition



4S 40A
Enhanced Edition

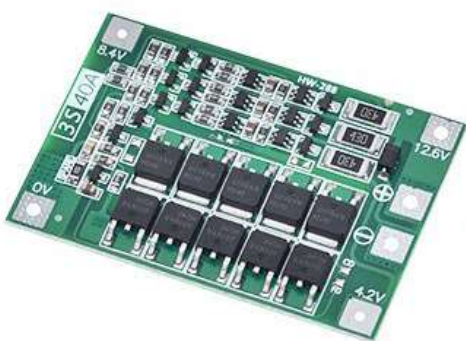

3S 40A
Balanced version

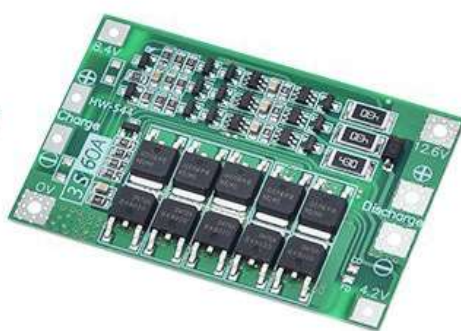

3S 60A
Balanced version

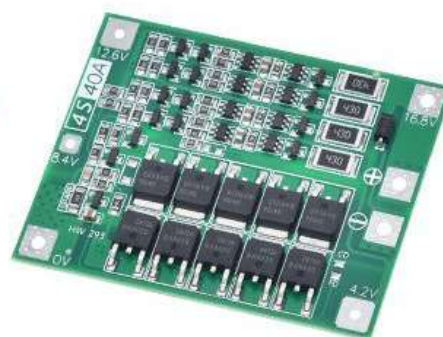

4S 40A
Balanced version

The figure below shows the module discharge diagram. The battery is 3 strings. The connected battery needs to meet the 40A discharge current. It can be realized by paralleling the battery or purchasing a battery with a large discharge current. For example, if the battery is 2000mAH and the discharge multiple is 10C, then only 3 strings of 2 are needed and the discharge current is 40A.

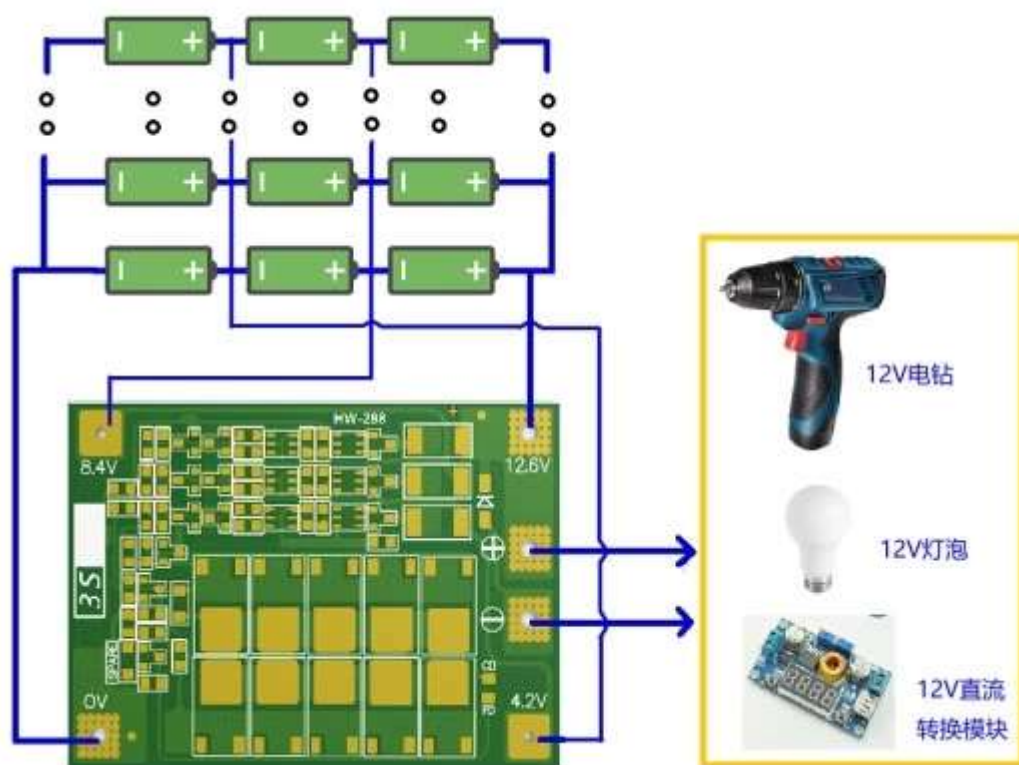

The figure below shows the battery charging diagram. The charging voltage is DC12.6V~13.6V. The charging current depends on the battery connected, and the maximum is no more than 20A. The module has a balanced charging path, and the equalization function works only when the battery performance is not much different.

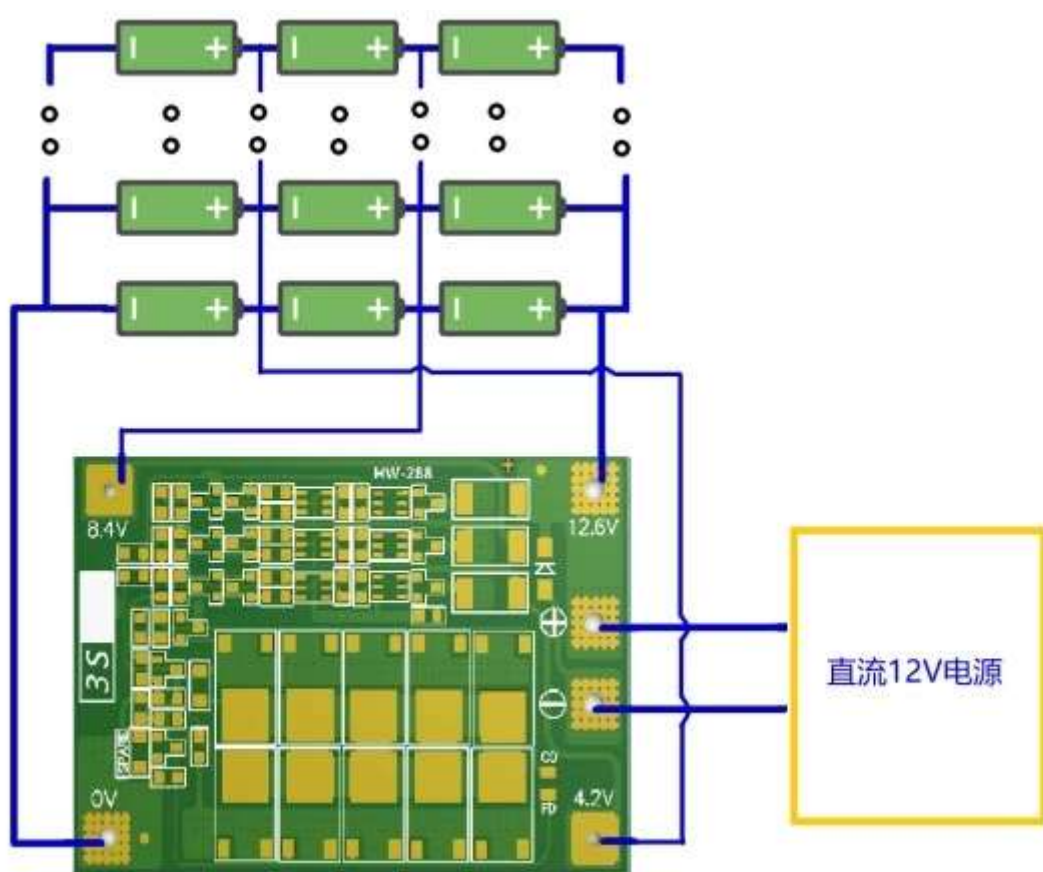
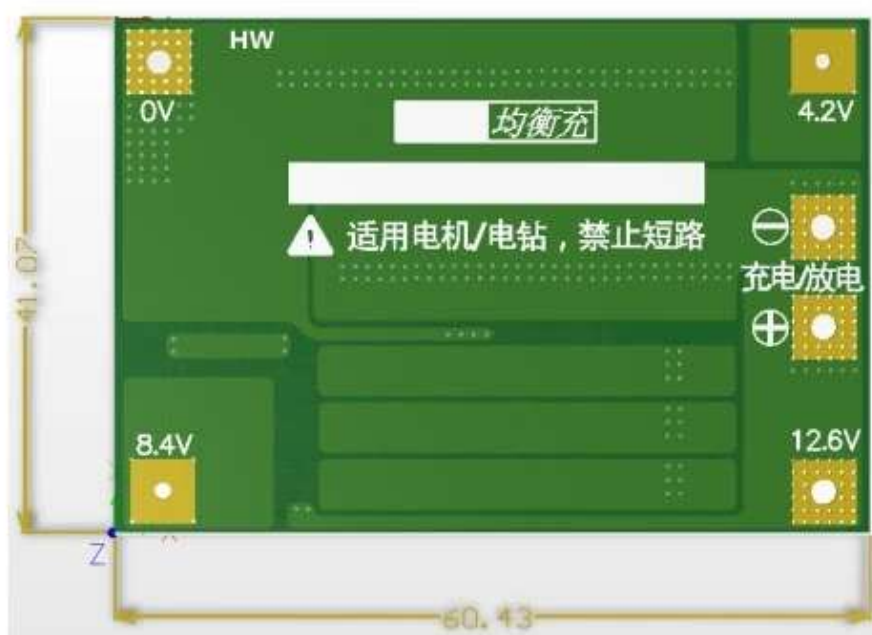
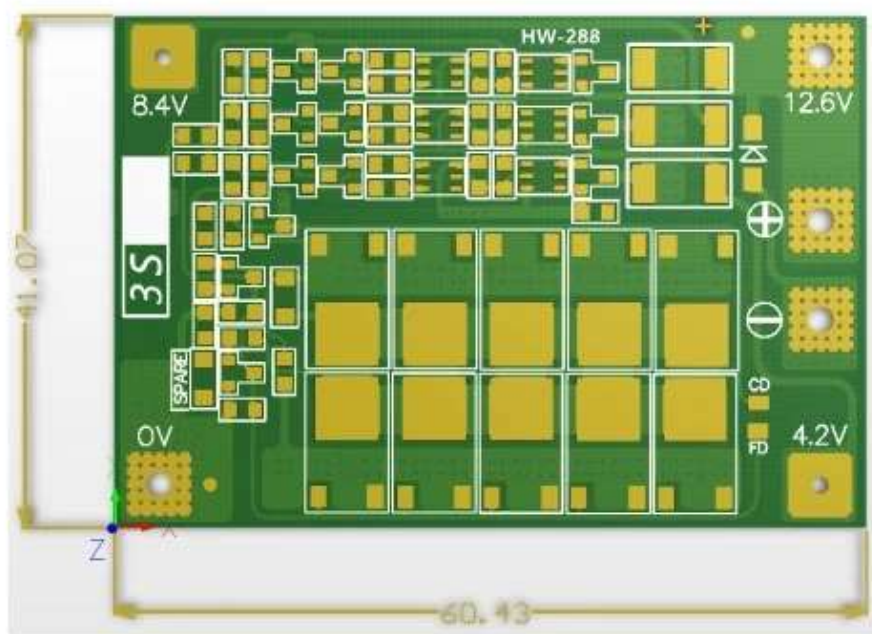

Description:

Product Name: 4 string 14.8V 16.8V 40A lithium battery protection board

Charging voltage: DC 16.8V~17V

Continuous discharge current: 40A maximum (if the heat dissipation environment is not good, please reduce the load current)

Continuous charging current: up to 20A

Balance Version Product size: 45*60*4mm

Enhance Version Product size: 44*55*4mm

Applicable choice: applicable to the nominal voltage of 3.7V, fully charged 4.2V

lithium battery

(including 18650, 26650, polymer lithium battery), can be drilled below 170W

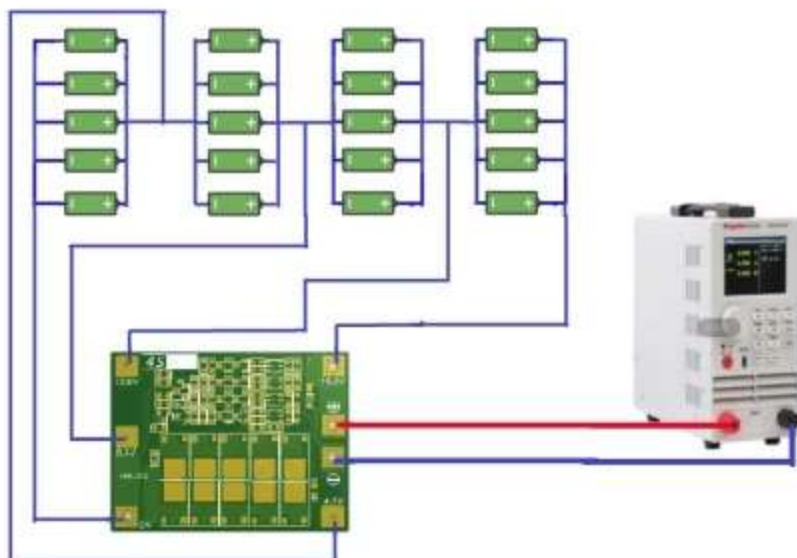
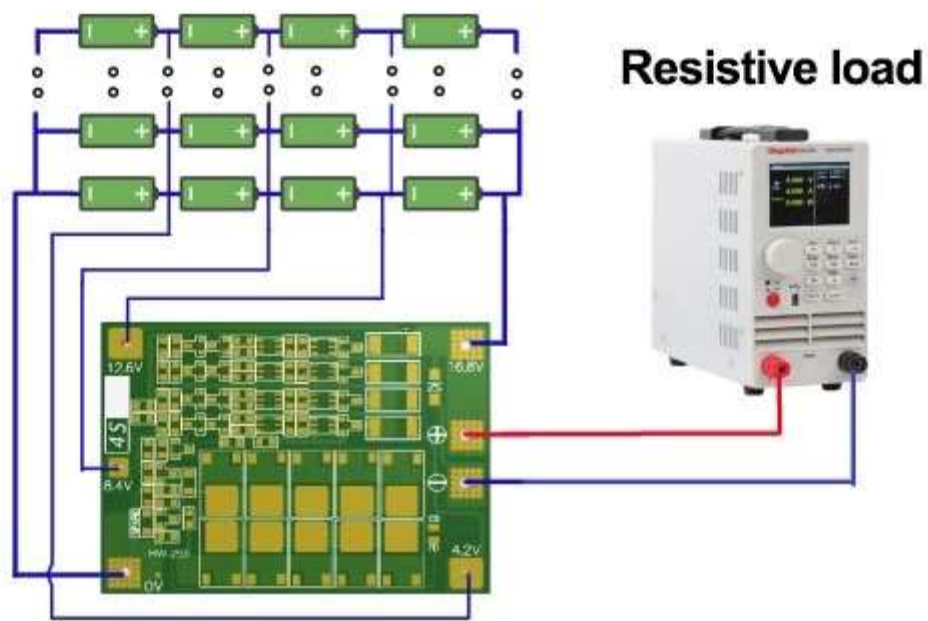

The picture below shows the battery charging diagram, 4 series of batteries, the actual full charge, voltage 16.8V, charging voltage DC17V-18V, charging current depends on the battery connected, the maximum does not exceed 20A.

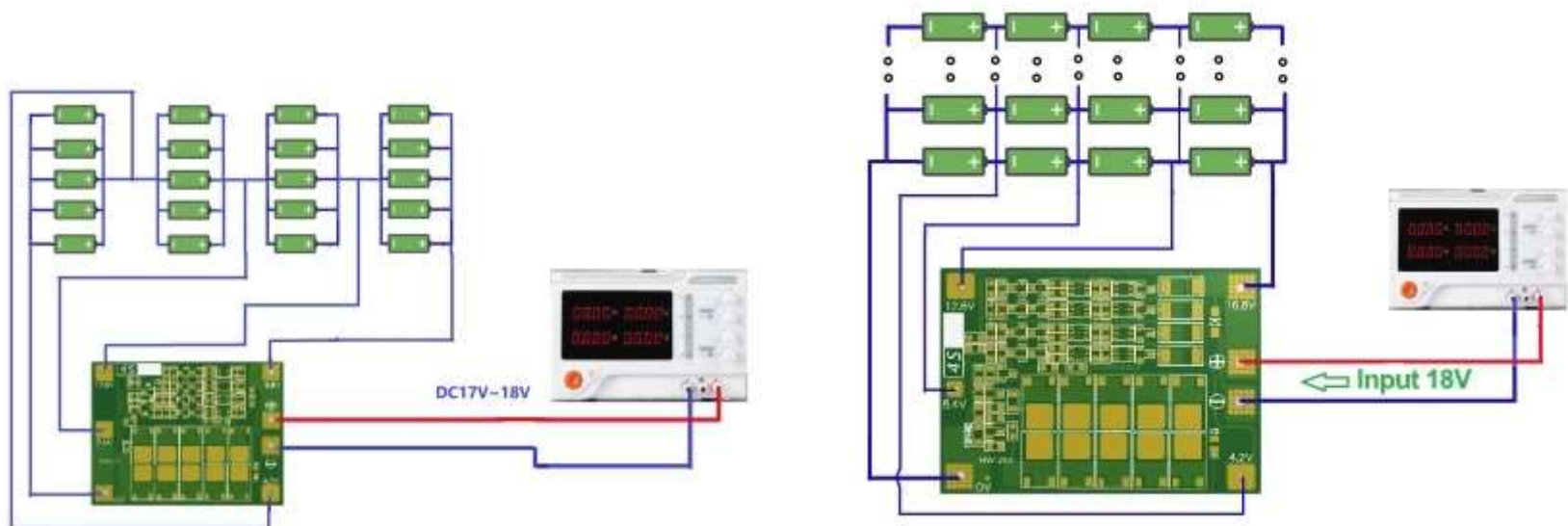

Features:

Product model: HW-552;

Size: 41 * 60 * 1mm;

Charging voltage: 12.6V-13V;

Maximum working current: 60A (heat dissipation conditions are very good);

Continuous charging current (upper limit): 20A;

Continuous discharge current (upper limit): 40A;

Overcurrent protection: 125A;.

Overcharge detection: 12.8V (for 3 groups of batteries);

Overcharge release: 12.3V (for 3 groups of batteries);

Overdischarge detection: 2.4V (for 1 group of batteries);

Overdischarge release: 3.0V (for 1 group of batteries);
Short circuit protection: Yes;
Working temperature: -40-- + 85C;
Storage conditions: -40-- + 125C.

Three usage scenarios:

A. Charging (overcharge protection)

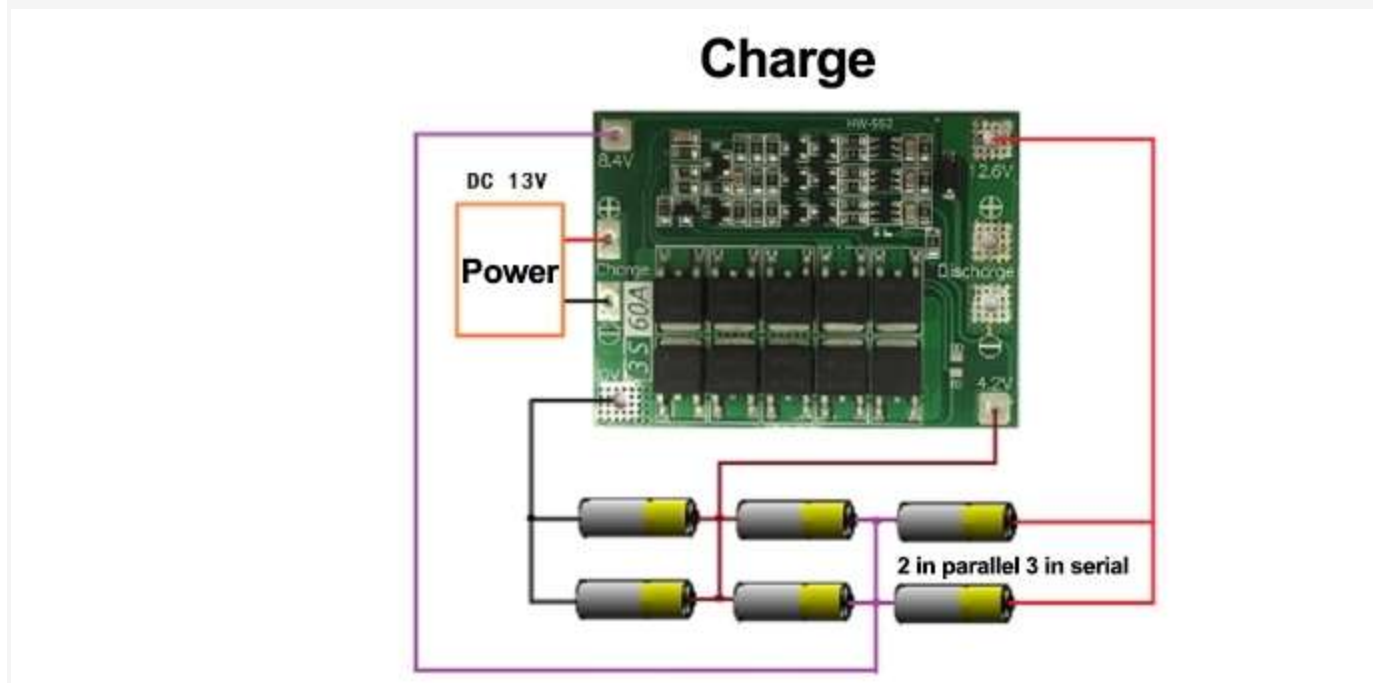

B. Discharge (overdischarge protection)

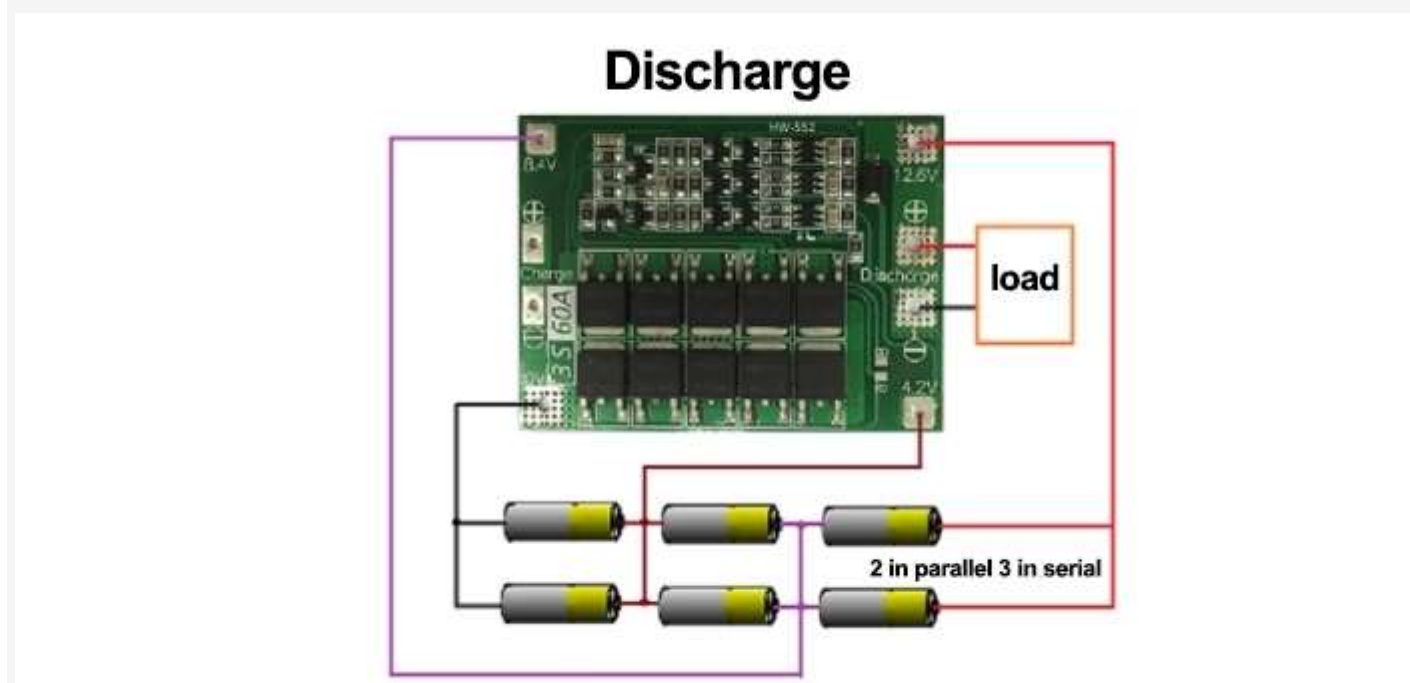

C. Overcurrent protection.

